

SURFBOARDS®

THE BREADBOARDING MEDIUM FOR **SURFACE MOUNT™**



33000 SERIES APPLICATION SPECIFIC ADAPTERS

IDS33505
REV A-10-2011

MODEL **33505** ACCEPTS **SC-70-5, SC-88A, SOT-323-5, SOT-353**

PARTIAL LISTING

5 LEAD .65 mm PITCH DEVICES
DEVICE LEAD WIDTH 2.1 To Max 3.8 MM

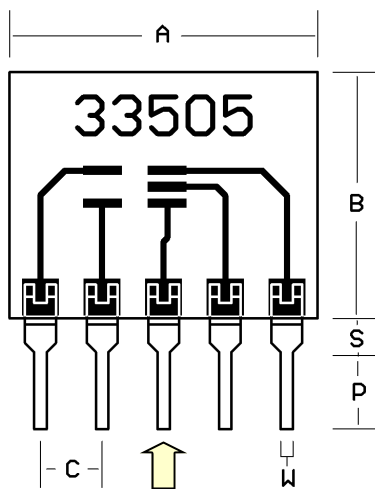

DRAWINGS
NOT TO
SCALE

**SINGLE-IN-LINE (SIP) PINS
ON .100 in. CENTERS**

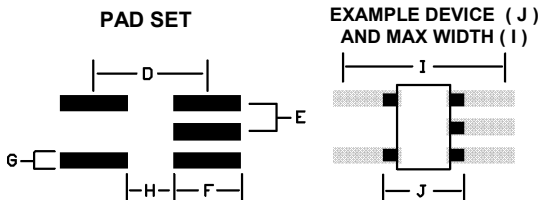

**MOUNTING PADS ARE OVERSIZED IN LENGTH TO
ACCEPT A WIDER RANGE OF DEVICE WIDTHS AND
TOLERANCES AND TO PERMIT HAND SOLDERING.
SEE WEBSITE FOR SOLDERING SUGGESTIONS**

BOARD SPECIFICATIONS

BOARD MATERIAL: .8mm, +/- .13mm .031in +/- .005 in.
Thick G-10 FR-4 Glass Epoxy or equivalent.

CIRCUITS: 1 oz. Copper with RoHS compliant Lead Free
solder coating. Patten Position on board +/- .5mm .020in.



- KEC **USV**
- PANASONIC **SMini5-F1, SMini5-G1
SMini5-DA**
- RENESAS **CMPAK-5 (T)**
- ROHM **UMD5, UMT5**
- TEXAS INST. **DCK (R-PDSO-N5)**
- TOSHIBA **UFV, USV**

ALWAYS CONSULT DEVICE DATA SHEET TO INSURE PROPER FIT

Feature Pins on .1 in. Centers designed for use with Solderless breadboards, Conventional Breadboards, and Sockets with standard .1 in. centers. Use For Prototyping, Device Test or Evaluation and SMD to Through Hole Conversion.

FIG.	MM	IN.	NOTE:
A	12.7	.500	BOARD WIDTH +/- .5mm .020in.
B	10.16	.400	BOARD HEIGHT +/- .5mm .020in.
C	2.54	.100	SIP PIN SPACE +/- .20mm .008in.
D	2.7	.106	PAD CENTERLINE
E	.65	.025	DEVICE LEAD PITCH
F	1.6	.063	PAD LENGTH
G	.4	.016	PAD WIDTH
H	1.1	.043	GAP
I	3.8	.149	MAX LEAD WIDTH
J	2.1	.082	TYPICAL LEAD WIDTH
P	3.3	.130	LENGTH FROM SHOULDER +/- .5mm .020in.
S	1.57	.062	PIN SHOULDER HEGHT
W	.5	.020	PIN WIDTH

TOLERANCES: If not noted are +/- 20%. Nominal values are given. Controlling unit is Millimeters. Values rounded to nearest decimal. Slight Variations due to manufacturing process can occur.

Copyright 2011 by Capital Advanced Technologies, Inc. All rights reserved. Surfboards is a registered trademark of Capital Advanced Technologies, Inc. The Breadboarding medium for surface mount, and the Leaf Circuit Logo are trademarks of Capital Advanced Technologies, Inc. All other trademarks are the property of their respective owners. Specifications, availability, and price is subject to change without notice. All information given is believed to be accurate but is not guaranteed. The user of information given or products represented by such information is responsible for determining the suitability of said information or products for a given purpose. No inducement is intended or permission granted for infringement of any patent or unauthorized use of any intellectual property of Capital Advanced Technologies or others.

CAPITAL ADVANCED TECHNOLOGIES, INC.
CAROL STREAM, ILLINOIS. USA PHONE 630-690-1696 FAX 630-690-2498
WWW.CapitalAdvanced.Com

MADE
IN
USA